



# SC180HEU Owner's Manual

---



## **BILLY GOAT SOD CUTTER Owner's Manual**

SC180HEU

Beginning Serial #: 100515001

### **Original Instructions**

**IMPORTANT- READ CAREFULLY BEFORE USE AND KEEP FOR FUTURE REFERENCE**



## SC180HEU Owner's Manual

---

### ABOUT THIS MANUAL

**THANK YOU** for purchasing a BILLY GOAT® *Sod Cutter*. Your new machine has been carefully designed and manufactured to provide years of reliable and productive service. This manual provides complete operating and maintenance instructions that will help to maintain your machine in top running order. Read this manual carefully before assembling, operating, or servicing your equipment.

### CONTENTS

SERIAL PLATE DATA AND SPECIFICATIONS _____	3
SOUND AND VIBRATION _____	4
INSTRUCTION LABELS _____	5
PACKING CHECKLIST & ASSEMBLY _____	6
OPERATION CONTROLS/OPERATION _____	7-8
MAINTENANCE _____	9-10
TROUBLESHOOTING AND WARRANTY PROCEDURE _____	11
ILLUSTRATED PARTS & PART LISTS _____	12-20
DECLARATION OF CONFORMITY _____	21-23



# SC180HEU Owner's Manual

## SERIAL PLATE DATA

Record the model number, serial number, date of purchase, and where purchased.

Purchase Date: \_\_\_\_\_

Purchased From: \_\_\_\_\_

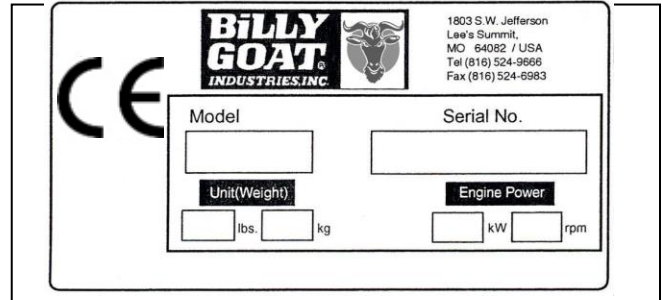

## SPECIFICATIONS

### SC180HEU

Engine: HP	5.5 HP (4.1 kw)
Engine: Model	GXV160UH2N1AH
Engine: Type	Honda
Engine: Fuel Capacity	1.6 qt. (1.5 L)
Engine: Oil Capacity	0.69 qt. (0.65 L)
Total Unit Weight:	348# (158 Kg)
Max. operating slope	20°
Overall length	54" (1371mm)
Overall width	26.5" (660mm)
Overall height	36.5" (927mm)
In accordance with 2000/14/EEC	104dBa
Sound at operators position	84dBa
Vibration at operator position	2.5g (24.8m/s <sup>2</sup> )



# SC180HEU Owner's Manual

## SOUND



L<sub>WA</sub>

104 dB(a)

SOUND LEVEL 84 dB(a) at Operator Position

Sound tests were conducted in accordance with 2000/14/EEC, and were performed on 7-11-13 under the conditions listed below.

**⚠** Sound power level listed is the highest value for any model covered in this manual. Please refer to serial plate on the unit for the sound power level for your model.

General Conditions:	Sunny
Temperature:	84°F (28.9°C)
Wind Speed:	10 mph (16.1 kmh)
Wind Direction:	East Southeast
Humidity:	37%
Barometric Pressure:	30.04 Hg (101.7 kpa)

## VIBRATION DATA

VIBRATION LEVEL 2.5 g (24.8 m/s<sup>2</sup>)

Vibration levels at the operator's handles were measured in the vertical, lateral and longitudinal directions using calibrated vibration test equipment. Tests were performed on 7-11-13 under the conditions listed below.

General Conditions:	Sunny
Temperature:	84°F (28.9°C)
Wind Speed:	10 mph (16.1 kmh)
Wind Direction:	East Southeast
Humidity:	37%
Barometric Pressure:	30.04 Hg (101.7 kpa)

## INTENDED USE

### INTENDED USE

This machine may only be utilized for the purpose for which it was designed, i.e. to cut 18in (45.7 cm) wide strips of turf. Make sure that all operators of this equipment are trained in general machine use and safety.

**WARNING:** During operation the lawn and turf are cut into strips. Should the cutter's wheels skid during use it is advisable to adjust the cutting depth. If this operation does not prevent this occurrence check the state of the terrain. If it is too dry it should be wetted so that the blade encounters a slight resistance, thus making cutting operations easier.



# SC180HEU Owner's Manual

## INSTRUCTION LABELS

The labels shown below were installed on your BILLY GOAT® Sod Cutter. If any labels are damaged or missing, replace them before operating this equipment. Item numbers from the Illustrated Parts List and part numbers are provided for convenience in ordering replacement labels. The correct position for each label may be determined by referring to the Figure and Item numbers shown.



**LABEL DANGER KEEP HANDS AND FEET AWAY**  
P/N 400424



**LABEL TIE DOWN**  
P/N 371505



**LABEL WARNING GUARDS**  
P/N 900327

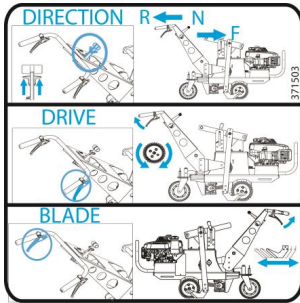

**LABEL INSTRUCTION DRIVE**  
P/N 371503

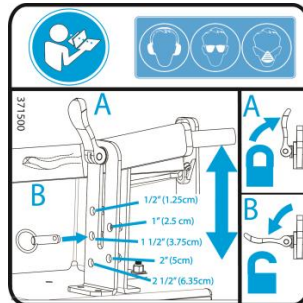

**LABEL INSTRUCTION DEPTH**  
P/N 371500

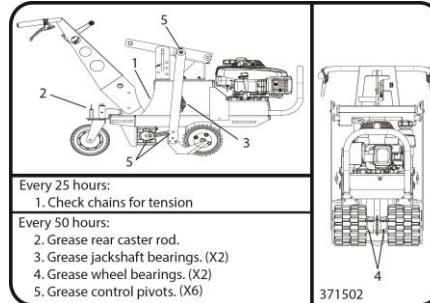

**LABEL GREASE POINTS**  
P/N 371502

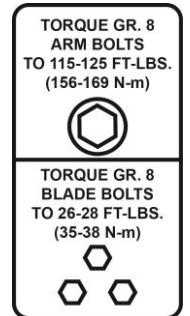

**LABEL TORQUE**  
P/N 371524

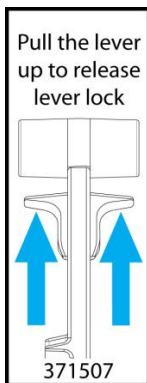

**LABEL SHIFTER CONTROL**  
P/N 371507

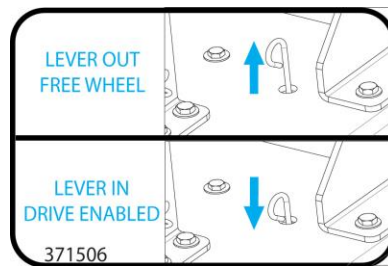

**LABEL DRIVE RELEASE**  
P/N 371506

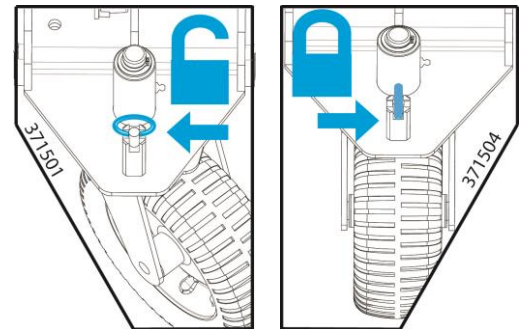

**LABELS CASTER LOCK**  
P/N 371501 & 371504



**LABEL HANDLE DRIVE**  
P/N 371514



# SC180HEU Owner's Manual

## PACKING CHECKLIST

Your Billy Goat Sod Cutter is shipped from the factory in one crate, completely assembled.



**READ** all safety instructions before assembling unit.  
**TAKE CAUTION** when removing the unit from the box.



**PUT OIL IN ENGINE BEFORE STARTING**

**CHECK GREASE IN BEARING PER SERVICE LABEL ON UNIT. ADD GREASE AS REQUIRED. USE NLGI GRADE 2 MULTIPURPOSE LITHIUM BASE GREASE**

### PARTS BAG & LITERATURE ASSY

Warranty card P/N- 400972, Owner's Manual P/N-371515, Declaration of conformity P/N- 371509, General Safety and Warranty manual P/N- 100295

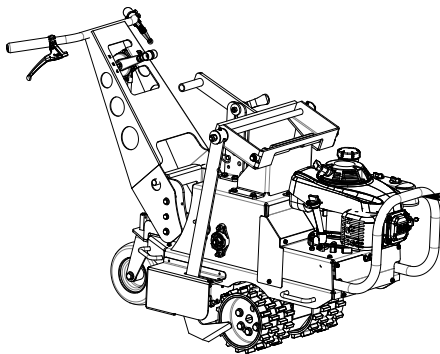

**Boxing Parts Checklist**

Honda 5.5 HP engine

## OPERATOR CONTROLS

**DRIVE CONTROL:** Located on the right hand side of the handle bars. When engaging the drive lever, pull it till it comes into contact with the handle bar. Do not halfway engage the drive as this will cause premature failure of the transmission. (See Fig. 1)

**BLADE ENGAGE LEVER:** Located on the left hand side of the handle bar. As with the drive lever, it must be fully engaged when in use.

**SPEED AND DIRECTON SHIFTER:** Lift the levers located on either side of the shifter control then move the shifter control forward or backward to select the desired direction and speed then release the levers. DO NOT push the shifter control without releasing the levers as this will cause damage to the shifter control. (See Fig. 2)

**FREE WHEEL LEVER:** Located on top of machine next to the height adjust. Pull the lever out to free wheel and push it in to allow the drive to be engaged. (See Fig. 3)

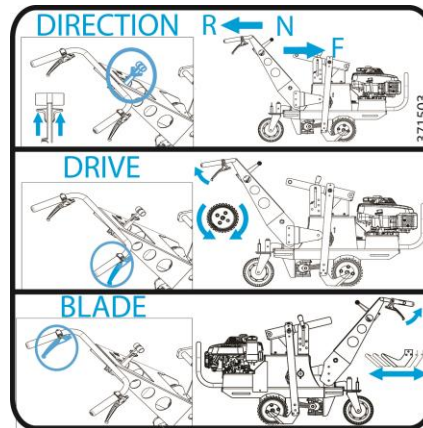

Fig. 1

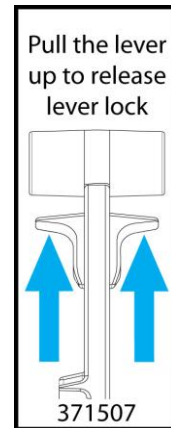

Fig. 2



Fig. 3





# SC180HEU Owner's Manual

## OPERATION

Note: Item numbers in ( ) will be referenced in the Parts Illustration and Parts List on pages 12-20

Like all mechanical tools, reasonable care must be used when operating machine.

**Inspect machine work area and machine before operating. Make sure that all operators of this equipment are trained in general machine use and safety.**

**PUT OIL IN ENGINE BEFORE STARTING**

### STARTING ENGINE

See engine manufacturer's instructions for type and amount of oil and gasoline used. Engine must be level when checking and filling oil and gasoline.

ENGINE SPEED: Engine speed is fixed.

FUEL VALVE: Move fuel valve to "ON" position.

CHOKE: Found on engine above fuel on switch.

PULL: Pull the starting rope to start engine.

FORWARD CONTROL AND BLADE MOVEMENT LEVERS: See page 8 Operator's Controls.

**Do not operate if excessive vibration occurs. If excessive vibration occurs, shut engine off immediately and check for damaged or worn blade, loose blade bolts, loose engine or lodged foreign objects.**

### HANDLING & TRANSPORTING

Use loading ramps to move unit into truck or trailer for transport. **DO NOT** operate the blade when loading.

Never load this machine by hand.

### CUTTING OPERATION

The unit performs best when the ground is wet. If possible sprinkle the work area several hours before starting.

**CAUTION**: Shut off the blades when crossing gravel drives, walks or roads and under all conditions where thrown objects might be a hazard.

**CLEARING DEBRIS FROM UNDERSIDE OF MACHINE**: Turn engine off and wait for blade to stop completely. Disconnect spark plug wire and place the unit in gear to prevent the unit from rolling.

Wearing durable gloves, remove debris. **Danger**, the debris may contain sharp materials. Reconnect spark plug wire.

**CAUTION**: Use extreme care when operating the blade. Inspect the work area for foreign objects that could cause damage to the unit or injure the operator if struck by the blade. Never operate the blade with bystanders in the work area.

### GENERAL OPERATION

Position the turf cutter outdoors on sufficiently firm, flat soil. Read the instructions provided by the engine manufacturer in the relative manual and follow them carefully to prevent situations arising which may endanger either persons or the machine.

**WARNING: When using the machine for the first time it is advisable to get the feel of it by executing maneuvers on flat ground free of foreign objects.**

After switching on the engine following the instructions given in the previous paragraph:

**WARNING: DO NOT adjust cutting depth while machine is in motion. Choose a cutting depth suitable for the type of terrain the machine is to be used on.** Cutting height is set using the removable pin and placing it into the desired slot for depth. Then loosening the locking lever to allow the arm to be raised or lowered. The arm should be resting against the pin for the desired cutting height. Make sure to engage the locking lever before blade operation.

Operation continued next page.



## SC180HEU Owner's Manual

1. Choose a depth of cut. See instruction label on the unit (see *fig 4*). *Note:* Sod should be cut leaving a minimum amount of dirt (1/4"-3/8") attached to the roots. This minimizes its weight for removal and encourages faster growth when reused.
2. Holding both handles, fully engage the blade clutch lever on the operator's left hand side. Rocking back on the handles, allow the blade to cut into the sod to your chosen depth. Keep the blade clutch lever fully engaged at all times when cutting (see *fig 5*).
3. Using the ground speed and direction adjustment lever in the middle of the handle, set forward ground speed to a slow forward speed to begin.
4. Fully engage the ground drive clutch lever on the operator's right hand side. The unit will begin to move forward and cut a strip of sod.
5. As ground conditions allow, increase the ground speed using the speed control lever, in small increments until you attain the maximum speed of cut for your application. If the engine RPM drops significantly lower the forward speed until the engine comes back up to speed.
6. When you reach the end of the strip you are cutting, release both clutch levers and the unit will come to a stop. Using the blade depth adjustment handle raise the blade to the maximum height possible and lock it in place.
7. Fully engage both blade drive and ground drive clutch levers and the unit will drive forward and complete the cut of the strip.
8. Release the blade clutch lever and continue to drive the unit forward into position for the next cut, repeat the process above as required.

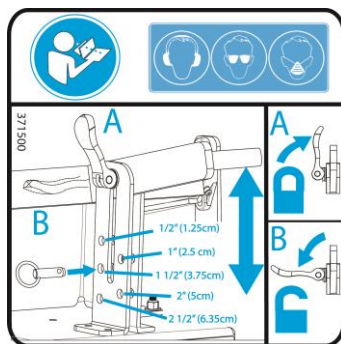

Fig. 4

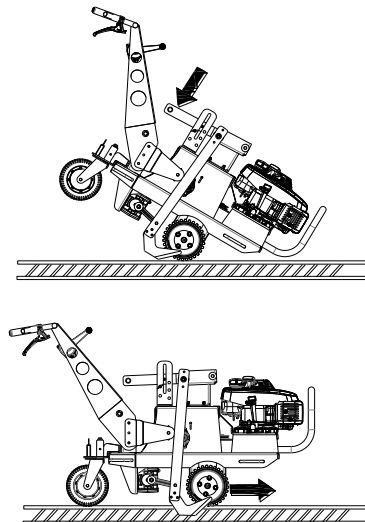

Fig. 5

### \*\*\*\*\*TIPS\*\*\*\*\*

Before commencing cutting operations, read the safety instructions given in the previous sections.

At first the setting of a relatively shallow cutting depth is recommended and then lowering it gradually according to working conditions.

Engage the blade clutch only after having carried out the machine switch on and gear engagement operations.





# SC180HEU Owner's Manual

## MAINTENANCE

Note: Item numbers in ( ) will be referenced in the Parts Illustration and Parts List on pages 12-20.

### PERIODIC MAINTENANCE

Periodic maintenance should be performed at the following intervals (disconnect spark plug during maintenance):.

Maintenance Operation	Every Use (daily)	Every 5 hrs or (daily)	Every 25 Hrs	Every 50 Hrs (Yearly)	Every 150 Hrs
Inspect for loose, worn or damaged parts.	•				
Check for excessive vibration		•			
Inspect belt for wear				•	
Engine (See Engine Manual)					
Grease pivot points *Use NLGI grade 2 multipurpose lithium based grease				•	
Sharpen Blade			•		
Replace blade and traction belts					•

Note: Blade, and drive belts and chains are normal wear items. These should be inspected on a regular basis and replaced if worn. Also see your Billy Goat Dealer for servicing your machine.

### BELT REPLACEMENT

Note: See Fig. 3 for belt configuration

Switch off the engine and disconnect the spark plug wire before carrying out any maintenance or repair work on the machine.

If a belt is worn or breaks it should be replaced as follows:

Remove all of the metal guards (items 15, 16, 21 and 17) to allow easier access to the pulleys and belts.

Note: see pages 12, 14, 16, 18 and 20 for part illustrations

#### BLADE BELT

1. Disconnect the spark plug, and then remove the guards.
2. Remove the master link on the drive chain (Item 133) to allow the belt (item 132) to be slipped past.
3. Loosen the tension on the pulley (item 35) by loosening the nut and bolt holding it to the base. Do not completely remove the nut and bolt, as loosening it will allow the pulley to shift.
4. Walk the old belt off of the clutch (item 18) if necessary.
5. Replace with the new belt and reapply tension to it on the pulley loosened in step 3 then tighten it. Do not put too much tension on the belt as this will lead to premature wear.
6. Reinstall the chain onto the wheel drive by reinserting the master link.
7. Reinstall the guards.
8. Check for proper operation.

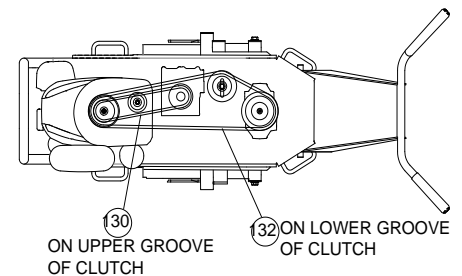

Fig. 3

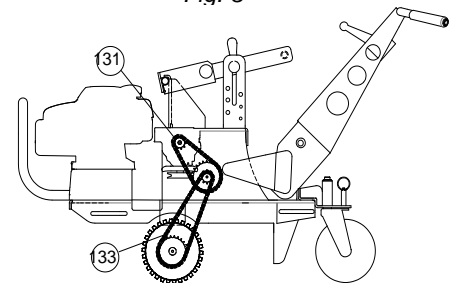

Fig. 4

See page 19 for parts illustration



## SC180HEU Owner's Manual

### DRIVE BELT

1. Follow steps 1-4 in the blade belt removal section. The blade belt will need to be removed in order to remove the drive belt.
2. Loosen the belt finger (119) on the idler arm (20) and remove the belt from the idler arm by lifting it over the idler pulley (39) and arm.
3. The belt will be loose enough now to walk it off of the transmission pulley (32). Remove the belt from the transmission pulley.
4. Disconnect the clutch cable (110) and then remove the bolt (114) holding the clutch (18) to the engine shaft.
5. Lower the clutch (18) enough and slide the belt off of the clutch groove and replace the old worn belt with a new one. Make sure it is sitting in the groove that the old one was removed from.
6. Reconnect the clutch back to the engine shaft. Make sure the anti-rotation bolt is in the small tube before reattaching. See page 15 for proper torque for the clutch bolt.
7. Reinstall all removed parts in the reverse order that they were removed.
8. Check for proper operation.

### CHECKING AND REPLACING THE BLADE

- Always check the state of the blade (item 44) before commencing work. Do not forget to switch the engine off!
- Remove the sparkplug wire.
- During work operations if the blade strikes stones or stumps stop straightaway and make sure that it has not become bent or broken. A damaged blade must be replaced.
- If the blade is very worn, cracked or bent, it may snap and project objects outwards, risking serious accident.
- Use heavy-duty work gloves to check or replace the blade to avoid risk of injury to hands.
- The blade fixing screws (item 81) and relative nuts (item 75) are also subject to wear. Always replace them at the same time as the blade, using bolts and screws of the same strength and type. Torque the bolts to 30 ft. lbs. (40.6 N.m)
- The blade wears more quickly on dry, sandy ground. In these conditions it should be replaced more frequently.

To remove the blade, proceed as follows:

1. Switch off the engine and disconnect the spark plug wire
2. Adjust the cutting height to maximum and remove the guards (items 140 and 143).
3. Check the state of the blade. Check that the blade is not cracked, bent, excessively worn or broken
4. When repair or check of blade is completed reattach spark plug

### CHECKS

- Adjust the belt and cable control tension after the first few working hours to account for initial break-in.
- Briefly operate all the machine's components to detect any abnormal noises or overheating.
- During the initial running in period avoid heavy-duty usage to encourage proper settling of the mechanical parts.
- Never neglect maintenance operations after work and carry out all pre-scribed checks regularly.

### CABLE CONTROL ADJUSTMENT

To adjust the cables place the machine on flat ground, switch off the engine and disconnect the wire from the spark plug.

### BLADE AND DRIVE CONTROL CABLES

Adjustments to the tension on the cables are made by adjusting the barrel length located on the handle. By extending the barrel more tension will be put on the cable. Make sure that you do not apply too much tension as this will cause premature failure or cause the lever to engage when it is not wanted.

*Note:* Apply lithium grease to the slots on the drive levers where the cable sits to help extend cable life.

### SHIFTER CONTROL CABLE

Position on the Shifter control cable (item 22) can be made by removing the rear cover and adjusting the barrel in or out depending on the desired position.





# SC180HEU Owner's Manual

## TROUBLESHOOTING

Problem	Possible Cause	Solution
Engine will not start	Choke not on. Out of gasoline, bad or old gas. Spark plug wire disconnected. Dirty air cleaner. Blade clutch is engaged	Check Gasoline. Check for spark with an approved tester. Clean or replace air cleaner. Disengage the Blade clutch lever.
Engine runs poorly	Spark plug wire loose. Carburetor out of adjustment. Water or dirt in fuel system. Spark plug fouled, faulty or wrong gap	Sharpen or replace blade. Adjust carburetor (refer to engine manual). Reset gap or replace spark plug (refer to engine manual).
Belt slips	Belt tension inadequate. Too deep of a working depth. Belt worn.	Replace belt. Replace blade
Abnormal vibration	Loose or out of balance blade. Bent blade. Loose engine bolts	Stop work immediately. Check blade mount and balance. Replace damaged or bent blade if required. Check engine mount.
Will not cut or has poor cutting performance	Dull or bent Blade. Debris locked against blade. Engine running at too low RPM. Sod is too dry.	Sharpen or replace blade. Remove debris. Check engine RPM (refer to engine manual). Apply more water to cutting area to loosen sod
Drive will not engage	Shifter in neutral. Out of adjustment drive cable. Broken drive cable. Worn or broken belt.	Shift lever to desired direction and speed. Adjust drive cable. Replace with new cable. Replace belt.
Drive will not release	Drive cable out of adjustment. Damaged drive lever.	Adjust drive cable. Replace drive cable.
Engine is locked, will not pull over	Debris locked against blade. Damaged engine.	Remove debris. Refer to engine owner's manual. Replace control cable.

When servicing engine refer to specific manufacturer's engine owner's manual. All engine warranty is covered by the specific engine manufacturer. If your engine requires warranty or other repair work contact your local servicing engine dealer. When contacting a dealer for service it is a good idea to have your engine model number available for reference (See table page 15). If you cannot locate a servicing dealer in your area you can contact the manufacturer's national service organization.

To reach:

**American Honda:** 800-426-7701

### WARRANTY CLAIM PROCEDURE

Should a BILLY GOAT<sup>®</sup> machine fail due to a defect in material and/or workmanship, the owner should make a warranty claim as follows:

- The machine must be taken to the dealer from whom it was purchased or to an authorized Servicing BILLY GOAT Dealer.
- The owner must present the remaining half of the Warranty Registration Card, or, if this is not available, the invoice or receipt.
- The Warranty Claim will be completed by the authorized BILLY GOAT Dealer and submitted to their respective BILLY GOAT Distributor for their territory Attention: Service Manager. Any parts replaced under warranty must be tagged and retained for 90 days. The model number and serial number of the unit must be stated in the Warranty Claim.
- The distributor service manager will sign off on the claim and submit it to BILLY GOAT for consideration.
- The Technical Service Department at BILLY GOAT will study the claim and may request parts to be returned for examination. BILLY GOAT will notify their conclusions to the distributor service manager from whom the claim was received.
- The decision by the Technical Service Department at BILLY GOAT to approve or reject a Warranty Claim is final and binding.

Make sure that the product is registered with Billy Goat. For online product registration go to [www.billygoat.com](http://www.billygoat.com)



# SC180HEU Owner's Manual

## SC180HEU ENGINE ASSEMBLY PARTS DRAWING

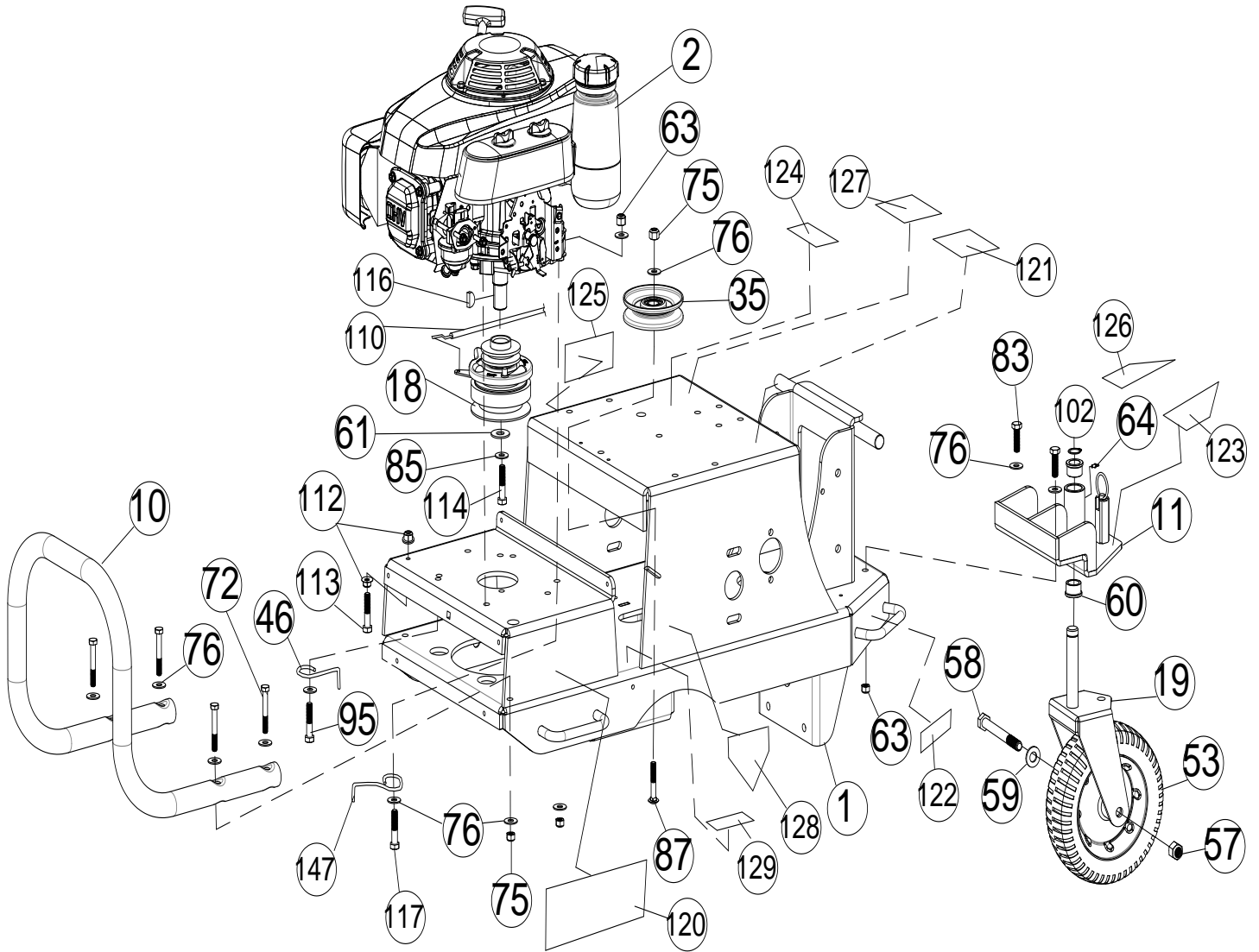



## SC180HEU Owner's Manual

### SC180HEU ENGINE ASSEMBLY PARTS LIST

Item no.	Part no.	Description	Qty
1	371100	FRAME WA SC	1
2	900615	ENGINE GXV 160	1
10	371400	TUBE BUMPER SC	1
11	371101	CASTER MOUNT WA	1
18	371264	CLUTCH SC	1
19	371102	CASTER RIG WA	1
35	520061	PULLEY IDLER 5L INSIDE 4"	1
46	371267	BELT FINGER	1
53	371206	WHEEL 8" X 3" HEAVY DUTY	1
57	8160005	NUT LOCK 1/2"-13 HEX	1
58	8041108	SCREWCAP 1/2"-13 X 4 3/4" HCS ZP	1
59	8172011	WASHER 1/2" SAE	1
60	520184	BUSHING FLANGE 1" OD X 3/4" ID	2
61	440153	WASHER 1.5" OD X .453 ID X .25 THK	1
63	8160003	NUT LOCK 3/8"-16	6
64	610363	GREASE ZERK	1
72	8041033	SCREWCAP 5/16"-18 X 2 1/4 GR 5 HCS ZP	4
75	8160002	NUT LOCK 5/16"-18	5
76	8171003	WASHER 5/16" FLAT	22
83	8041051	SCREWCAP 3/8"-16 X 1 1/4" HC ZP	2
85	8177012	LOCK WASHER 3/8" S/T MED	1
87	8024062	CARRIAGE BOLT 3/8"-16 X 2" ZP	1
95	8041031	SCREWCAP 5/16"-18 X 1 3/4" GR. 5 HCS ZP	1
102	520176	SNAP RING	1
110	371232-S	CABLE SPEED CONTROL LEFT SERVICE	1
112	900455	NUT WHIZ 1/4-20 WASH FACE	2
113	8041008	SCREWCAP 1/4"-20 X 1 1/2" HCS ZP	1
114	900344	SCREWCAP 3/8"-24 X 1 1/2" GR. 8 40-45 FT-LBS (54-61 N.m)	1
116	900162	KEY HI PRO 5/32 X 5/8"	1
117	400164	SCREWCAP 5/16"-24 X 1 " GR. 8 ZP W/PATCH	3
120	371510	LABEL BADGING SC	2
121	371503	LABEL INSTRUCTION DRIVE	1
122	371505	LABEL TIE DOWN	4
123	371501	LABEL CASTER LOCK LEFT	1
124	371506	LABEL DRIVE RELEASE SC	1
125	371502	LABEL GREASE POINTS SC	1
126	371504	LABEL CASTER LOCK RIGHT	1
127	371500	LABEL INSTRUCTION DEPTH	1
128	400424	LABEL DANGER	2
129	900327	LABEL WARNING GUARDS	4
147	371281	BELT FINGER TIGHT SIDE	1



# SC180HEU Owner's Manual

## SC180HEU BLADE ASSEMBLY PARTS DRAWING

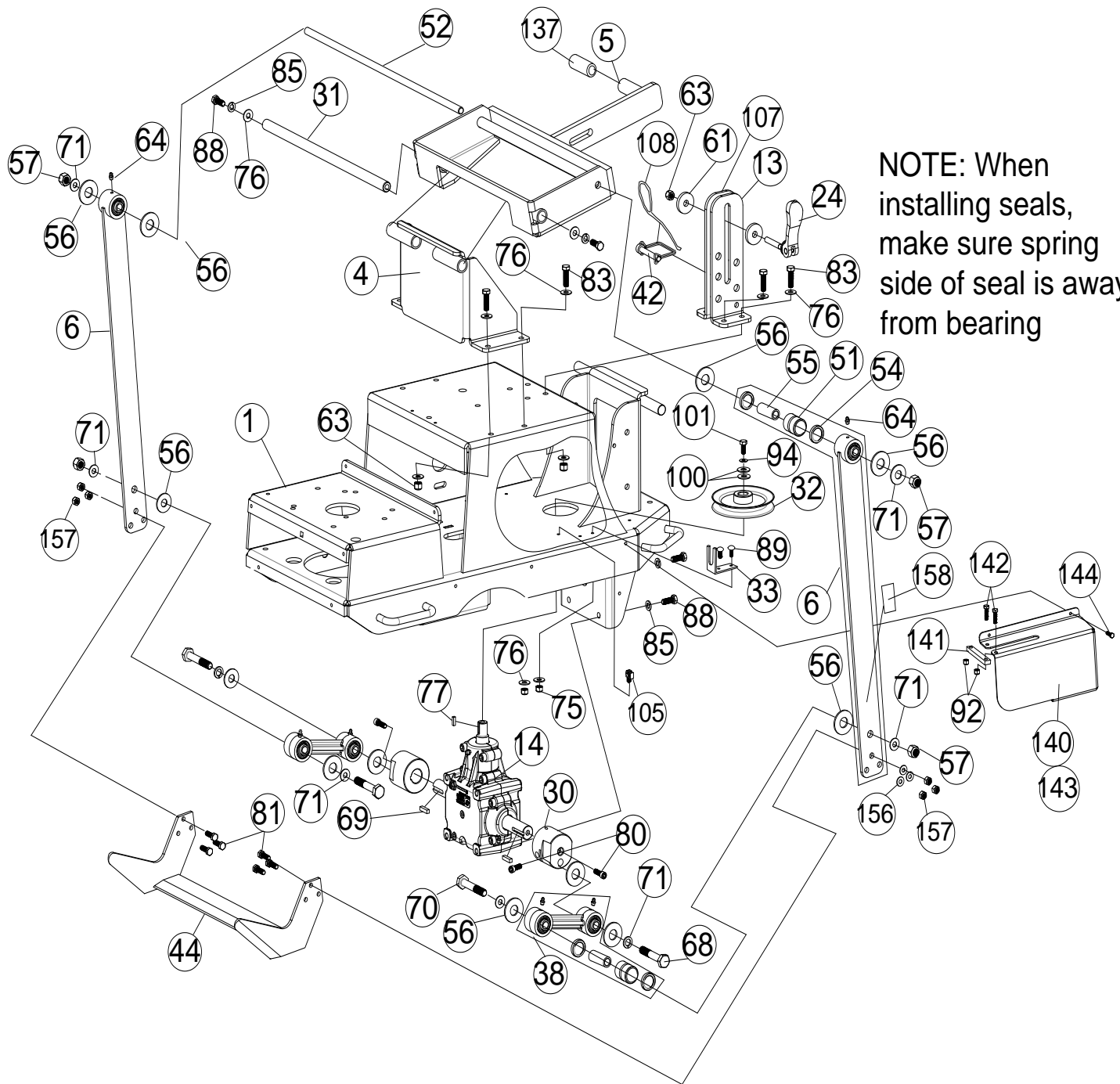

NOTE: When installing seals, make sure spring side of seal is away from bearing





## SC180HEU Owner's Manual

### SC180HEU BLADE ASSEMBLY PARTS LIST

Item no.	Part no.	Description	Qty
1	371100	FRAME WA	1
4	371107	PIVOT DEPTH WA	1
5	371106	BLADE DEPTH WA	1
6	371108-S	BLADE ARM SERVICE	2
13	371289	HEIGHT DEPTH BRACKET LH	1
14	371205	GEAR BOX "T" 2:1 REDUCTION	1
24	371219	LEVER CAM LOCK	1
30	371202-S	ECCENTRIC BLADE DRIVE SERVICE W/ITEM 80	2
31	371259	SHAFT PIVOT DEPTH	1
32	371215	PULLEY 5" X 3/4" BORE	1
33	371208	TAB MOUNT SHIFT CABLE	1
38	371216-S	ARM BLADE DRIVE SERVICE	2
42	371284	PIN WIRE LOCK DIA. 1/2" X 3" LG ZP	1
44	371203-S	KIT SC REPLACEMENT BLADE	1
51	371247	BEARING SC	6
52	371260	ROD BEARING	1
54	371252	SEAL GREASE	12
55	371257	BUSHING BEARING SC	6
56	371237	WASHER PLASTIC	14
57	8160005	NUT LOCK 1/2"-13 HEX	4
61	440153	WASHER 1.5 OD X .453 ID X .25	2
63	8160003	NUT LOCK 3/8"-16	9
64	610363	GREASE ZERK	8
68	8041110	SCREWCAP 1/2"-13 X 2 3/4" GR 8 ZP W/RED PATCH (TORQUE TO 115 FT. LBS)	2
69	9201113	KEY 1/4" SQ X 1"	2
70	8041111	SCREWCAP 1/2"-13 X 3" GR 8 ZP	2
71	8171006	WASHER 1/2" USS	8
75	8160002	NUT LOCK 5/16"-18	2
76	8171003	WASHER 5/16" FLAT	32
77	9201072	KEY 3/16" SQ X 5/8"	1
80	362289	SHCS 5/16"-18 X 1.25" BLK OX W/RED PATCH	4
81	8041043	SCREWCAP 5/16"-18 X 1" GR 8 ZP	6
83	8041051	SCREWCAP 3/8"-16 X 1 1/4" HC ZP	8
85	8177012	LOCK WASHER 3/8" S/T MED	6
88	8041050	SCREWCAP 3/8"-16 X 1" HCS ZP W/PATCH	6
89	8024040	CARRIAGE BOLT 5/16"-18 X 1" GR. 5 HCS ZP	2
92	8160001	NUT LOCK 1/4"-20 HEX	4
94	8177011	LOCK WASHER 5/16" S/T MED	1
100	8171004	WASHER 3/8" FC	2
101	8041026	SCREWCAP 5/16"-18 X 3/4" GR 5 HCS ZP	1
105	371222	CABLE CLAMP	4
107	371288	HEIGHT DEPTH BRACKET RH	1
108	371283	LANYARD 12" COATED STEEL	1
137	790179	GRIP 1" X 4"	1
140	371274	GUARD ROTATING ASSY LH	1
141	371408	BAR GUARD SUPPORT	2
142	8041004	SCREWCAP 1/4"-20 X 3/4" GR. 5	4
143	371273	GUARD ROTATING ASSY RH	1
144	371276	SCREW 1/4"-20 X 3/4" TAP TITE	6
156	8172008	WASHER 5/16" SAE	6
157	371286	NUT LOCK 5/16" HEX GR 8 (TORQUE 28FT. LBS.)	6
158	371524	LABEL TORQUE SC	2



## SC180HEU HANDLE ASSEMBLY PARTS DRAWING

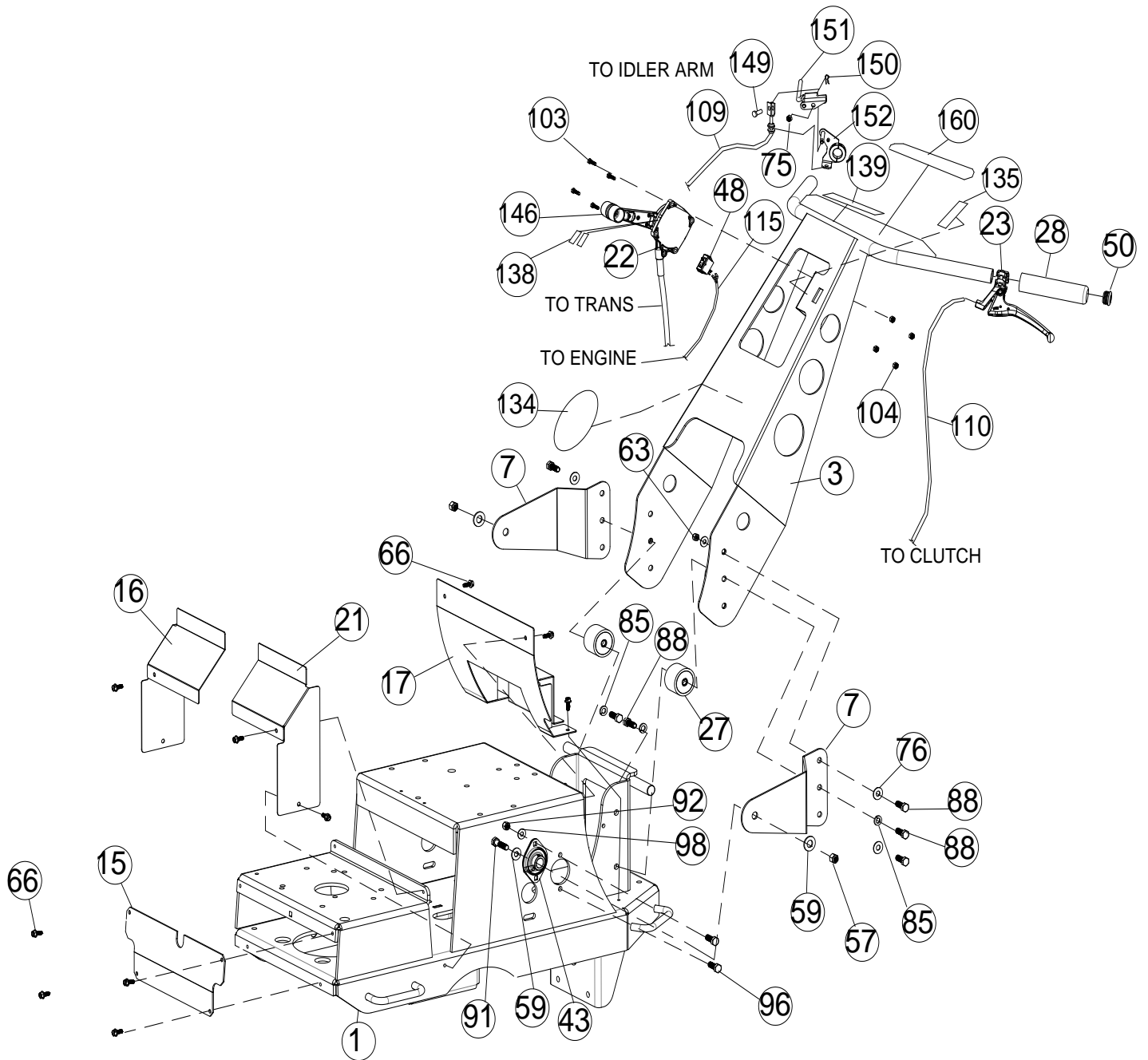



## SC180HEU Owner's Manual

### SC180HEU HANDLE ASSEMBLY PARTS LIST

Item no.	Part no.	Description	Qty
1	371100	FRAME WA	1
3	371613	HANDLE SC WA	1
7	371209	HANDLE BRACKET MOUNT	2
15	371207	GUARD FRONT	1
16	371242	GUARD MID RIGHT	1
17	371103	GUARD REAR WA	1
21	371233	GUARD MID LEFT	1
22	371204	SPEED CONTROL SC	1
23	351209	CONTROL LEVER DRIVE	2
27	371210	RUBBER HANDLE MOUNT	2
28	500267	GRIP 1" X 5.5"	2
43	891025	1/2" PRESSED STEEL HOUSING	2
48	500281	SWITCH TOGGLE	1
50	890132	PLUG TUBE 1"	2
57	8160005	NUT LOCK 1/2"-13 HEX	2
59	8172011	WASHER 1/2" SAE	2
63	8160003	NUT LOCK 3/8"-16	4
66	371276	SCREW SELF TAP 1/4"-20 X 3/4" TYPE 23	12
75	8160002	NUT LOCK 5/16"-18 X 1 3/4" HCS ZP	1
76	8171003	WASHER 5/16" FLAT	8
85	8177012	LOCK WASHER 3/8" S/T MED	4
88	8041050	SCREWCAP 3/8"-16 X 1" HCS ZP	8
91	8041097	SCREWCAP 1/2"-13 X 1 3/4 HCS ZP	2
92	8160001	NUT LOCK 1/4"-20	4
96	8041006	SCREWCAP 1/4"-20 X 1" HCS ZP	4
98	8171002	WASHER 1/4" FLAT	4
103	8059136	SCREW MACH #10-24 X 3/4 WF ZP	4
104	8155007	NUT LOCK #10-24 HEX	4
109	831227	CABLE CONTROL DRIVE QV	1
110	371232-S	CABLE CSPEED CONTROL LEFT SERVICE	1
115	360316	WIRE HARNESS	1
134	430303	LABEL PRODUCT LOGO CIRCLE LG	1
135	371507	LABEL SHIFTER CONTROL	1
138	371513	LABEL NEUTRAL SC18	2
139	371514	LABEL HANDLE DRIVE SC18	1
146	371279	HANDLE DRIVE SC18	1
149	440124	PIN CLEVIS 0.25 X 0.50	1
150	440193	PIN CLIP HITCH .051 X 3/4"	1
151	440277	ARM CONTROL WA	1
152	831115	CONTROL MOUNT HANDLE WA	1
160	371282	LABEL CONSOLE SC	1



## SC180HEU TRANSMISSION ASSEMBLY PARTS DRAWING

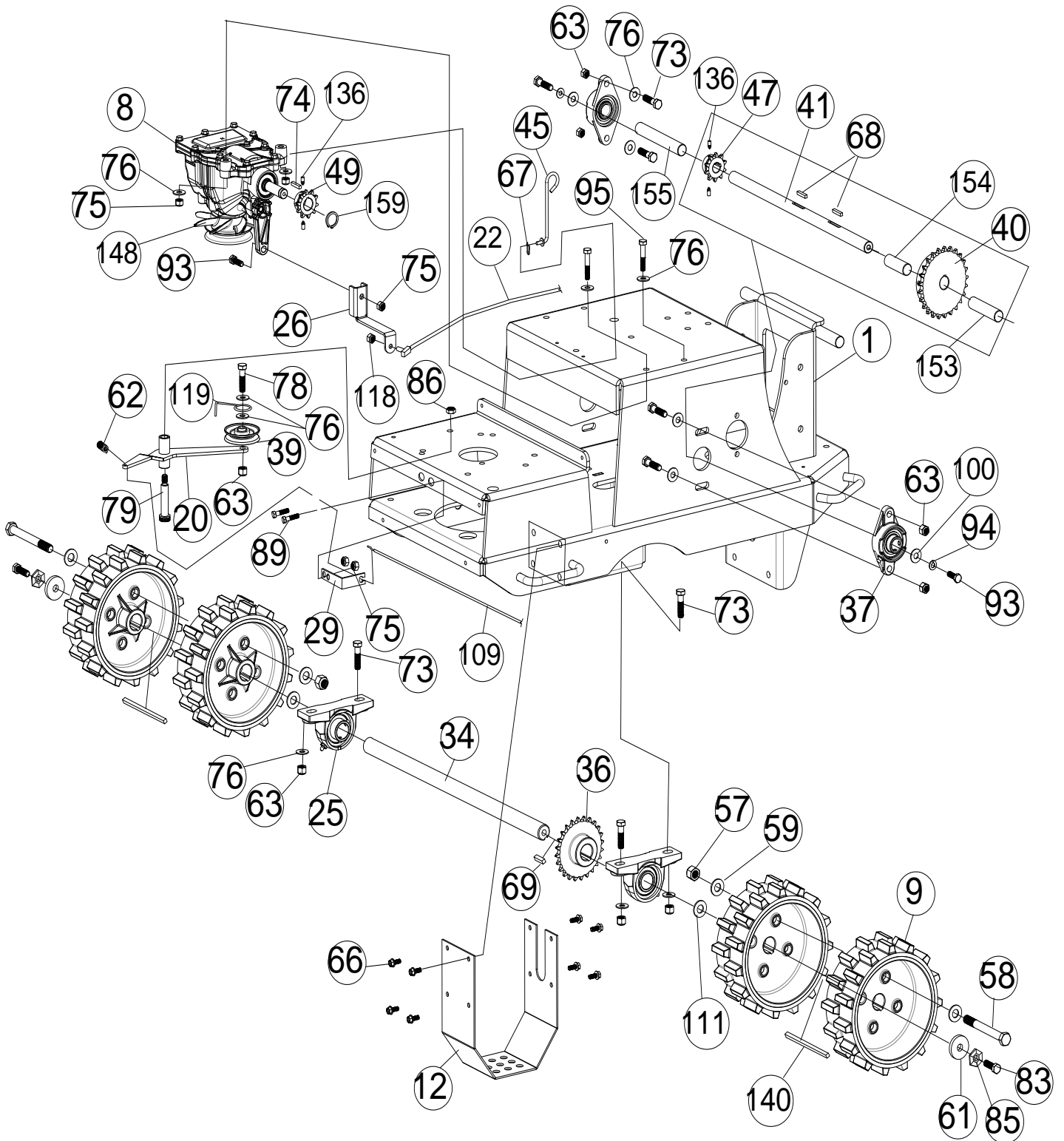



## SC180HEU Owner's Manual

### SC180HEU TRANSMISSION ASSEMBLY PARTS LIST

Item no.	Part no.	Description	Qty
1	371100	FRAME WA SC	1
8	371201	TRANSMISSION RT310	1
9	371200	WHEEL DRIVE SOD CUTTER	4
12	371211	GUARD AXLE	1
20	371105	IDLER ARM WA	1
22	371204	SPEED CONTROL SC	1
25	810700	PILLOW BLOCK 1"	2
26	371213	SHIFT ARM EXTENSION	1
29	371234	TAB MOUNT WHEEL CLUTCH CABLE	1
34	371277	AXLE LONG SC	1
36	371223	SPROCKET 40C25 1" BORE	1
37	350209	BEARING 3/4" CAST FLANGE W/ZERK	2
39	510137	IDLER PULLEY	1
40	371292	SPROCKET 40B25 1" BORE	1
41	371290	JACKSHAFT 1.00 X 17.06 LG X4140HT PLATED	1
45	371245	ROD TRANSMISSION BYPASS	1
47	371291	SPROCKET 40B10 1" BORE	1
49	371212	SPROCKET 40B10 5/8" BORE	1
57	8160005	NUT LOCK 1/2"-13 HEX	8
58	8041108	SCREWCAP 1/2"-13 X 4 3/4" HCS ZP	8
59	8172011	WASHER 1/2" SAE	16
61	440153	WASHER 1.5 OD X .453 ID X .25	2
62	800242	SPRING EXTENSION	1
63	8160003	NUT LOCK 3/8"-16	9
66	371276	SCREW SELF TAP 1/4"-20 X 3/4" TYPE 23	8
67	371275	PIN 1/4" RUE RING	1
69	9201113	KEY 1/4" SQ X 1"	3
73	8041052	SCREWCAP 3/8"-16 X 1 1/2" HC ZP	4
74	9201078	KEY 3/16" SQ X 1"	1
75	8160002	NUT LOCK 5/16"-18	5
76	8171003	WASHER 5/16" FLAT	14
78	8041054	SCREWCAP 3/8"-16 X 2" HCS ZP	1
79	520031	SHOULDER BOLT 1/2" X 2"	1
83	371278	SCREWCAP 3/8" - 16 X 1 1/4" GR 5 ZP W/RED PATCH	2
84	850233	SNAP RING TRUARC 5/8"	1
85	400502	WASHER LOCK 3/8" TWISTED TOOTH	2
86	8161042	NUT LOCK 3/8"-16 LT WT TH ZP	1
89	8041004	SCREWCAP 1/4" - 20 X 3/4" HCS ZP	2
93	8041028	SCREWCAP 5/16"-18 X 1" GR 5 HCS ZP	3
94	8177011	LOCK WASHER 5/16" S/T MED	2
95	8041032	SCREWCAP 5/16"-18 X 2" GR 5 HCS ZP	2
98	8171002	WASHER 1/4" FLAT	4
100	8171004	WASHER 3/8"FC	2
109	831227	CABLE CONTROL DRIVE QV	1
111	8172017	WASHER 1" SAE	2
118	8149001	NUT 1/4" - 28 HEX ZP	1
119	371269	BELT FINGER DRIVE IDLER PULLEY	1
136	8083122	SCREWSET 1/4"-20 X .375 CUP PT W/NYLOK	4
145	9201131	KEY 1/4" X 4.00"	2
148	371602	PULLEY AND FAN KIT RT310	1
153	371293	SPACER 1.25 X .109 WALL 3.35 LG	1
154	371294	SPACER 1.25 X .109 WALL X 2.787 LG	1
155	371295	SPACER 1.25 X .109 WALL X 6.578 LG	1
159	430226	RETAINING RING 5/8"	1



## SC180HEU Owner's Manual

### SC180HEU BELT AND CHAIN ASSEMBLY PARTS DRAWING

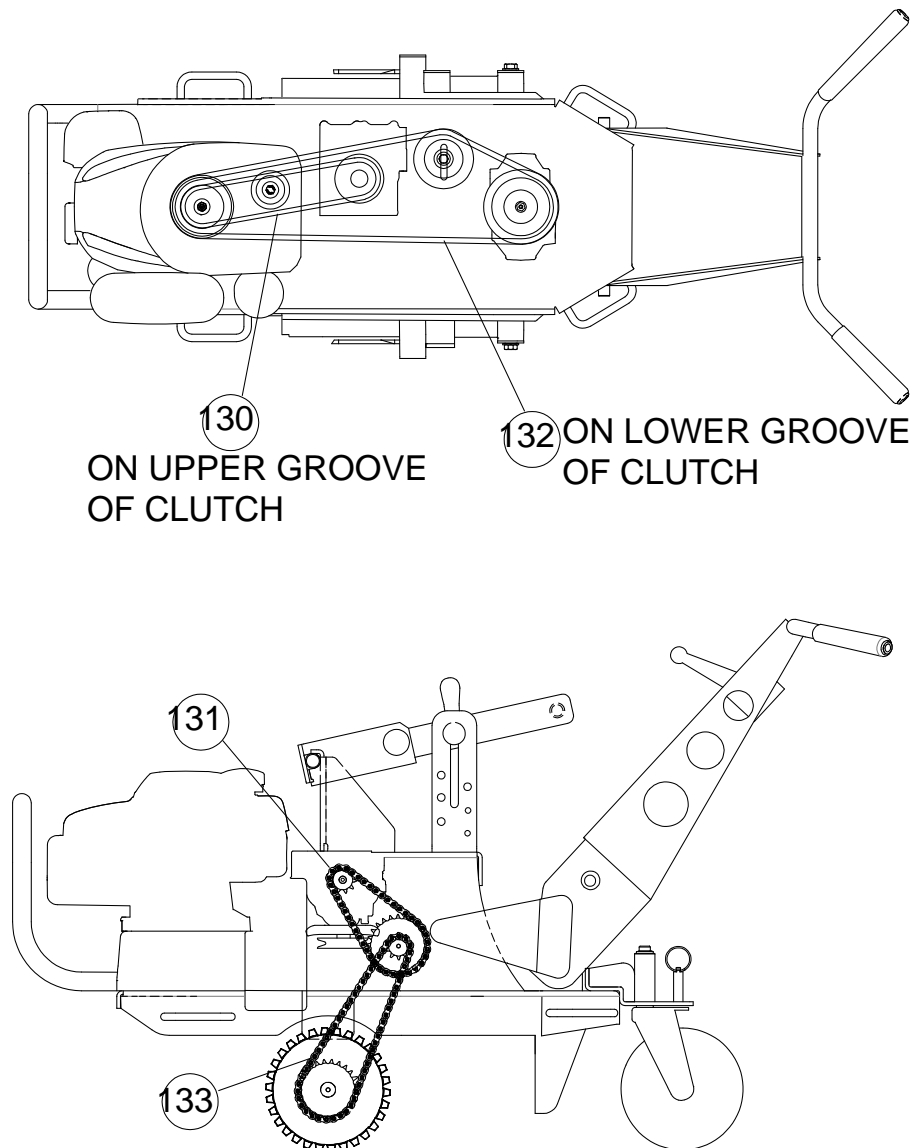

### SC180HEU BELT AND CHAIN ASSEMBLY PARTS LIST

Item no.	Part no.	Description	Qty
130	371270	BELT GATES 6732	1
131	371296	CHAIN #40 X 44 PITCHES	1
132	371246	BELT GATES 6958	1
133	371297	CHAIN #40 X 61 PITCHES	1





# SC180HEU Owner's Manual



en	English	fi	Suomi	lv	Latviešu	ru	Русский
bg	Български език	fr	Français	nl	Nederlands	sl	Slovenščina
cs	Čeština	el	Ελληνικά	no	Norsk	sk	Slovák
da	Dansk	hr	Hrvatski	pl	Polski	sv	Svenska
de	Deutsch	hu	Magyar	pt	Português	tr	Türkçe
es	Español	it	Italiano	ro	Română		
et	eesti keel	lt	Lietuvių				

en	EC Declaration of Conformity	el	Δήλωση συμμόρφωσης EK	pl	Deklaracja zgodności UE
bg	Декларация за съответствие с европейските стандарти	hu	EU Megfelelőségi nyilatkozat	pt	Declaração de Conformidade à CE
cs	ES Prohlášení o shodě	hr	EC Deklaracija o sukladnosti	ro	Declarație de conformitate C.E.
da	EC Overensstemmelseserklæring	it	Dichiarazione di conformità CE	ru	Заявление о соответствии стандартам и нормам EC
de	EG-Konformitätserklärung	lt	EB atitikties deklaracija	sl	ES izjava o skladnosti
es	Declaración de Conformidad de la CE	lv	EK Atbilstības deklarācija	sk	Vyhlasenie o zhode
et	Eü vastavustunnistus	nl	E.G. Conformiteitsverklaring	sv	EG-försäkran om överensstämmelse
fi	EC-vaatimustenmukaisuusvakuutus	no	CE konformitetserklæring	tr	EC Uygunluk Deklarasyonu
fr	Déclaration de conformité CE				

en	Category	Sod Cutter	el	Κατηγορία	έτοιμοι χλοοτάπητα Κάτερ	pl	Kategoria	darń do kosiarek
bg	Категория	копка Кътър	hu	Kategória	Gyep Cutter	pt	Categoria	sod cortador
cs	Kategorie	drnu Rezací ústrojí	hr	Kategorija	busen rezača	ro	Categorie	Sod de concasor
da	Kategori	græstørv lilder	it	Categoria	piota di taglierina	ru	Категория	дерново резак
de	Kategorie	Sodenschneider	lt	Kategorija	aeratorius	sl	Kategorija	rušo rezalec
es	Categoría	Sod cortador	lv	Kategorija	Danga pjaustyklē	sk	Kategória	sod Cutter
et	Kategooria	mätas kutter	nl	Categorie	plaggensteker	sv	Kategori	Ispadtaget Klippare
fi	Kategoria	Sod Cutter	no	Kategori	gresstorv kutter	tr	Kategori	çim Kesici
fr	Catégorie	de gazon Coupe						

en	This is to certify that the products listed in this document meet the requirements of the European Community Law, and can carry the CE mark. These models comply with the following Directives and related Standards.
bg	Декларацията се издава в удостоверение на това, че изброените продукти съответстват на стандартите на правните норми на Европейския съюз и могат да носят знака CE. Моделите изпълняват директивите и техните стандарти, както следва.
cs	Tímto stvrzujeme, že výrobky uvedené v tomto dokladu splňují požadavky zákonů Evropského společenství a mohou být označeny značkou CE. Tyto modely splňují následující směrnice a související normy.
da	Det bekræftes hermed, at de produkter, der er nævnt i dette dokument, opfylder bestemmelserne i EU-lovgivningen og kan bære CE-mærkatet. Disse modeller er i overensstemmelse med følgende direktiver og relaterede standarder:
de	Hiermit wird bescheinigt, dass die in diesem Dokument aufgeführten Produkte mit den gesetzlichen Bestimmungen der Europäischen Gemeinschaft übereinstimmen und das CE- Zeichen tragen können. Diese Modelle erfüllen die folgenden Richtlinien sowie weitere anzuwendende Normen.
es	La presente certifica que los productos enumerados en este documento cumplen con los requerimientos de la Legislación de la Comunidad Europea, y que pueden portar la marca CE. Estos modelos cumplen con las siguientes Directrices y Estándares relacionados:
et	Kinnitame, et eespool nimetatud tooted vastavad Euroopa Ühenduse seadusandluse nõuetele ja kannavad CE-märgistust. Eespool nimetatud mudelid vastavad järgmistele direktiividele ja seotud standardidele:
fi	Vakuutamme, että tässä asiakirjassa luetellut tuotteet täyttävät Euroopan Unionin lainsäädännön asettamat vaatimukset ja voi saada CE-merkinnän. Nämä mallit täyttävät seuraavien direktiivien ja niitä koskevien standardien vaatimukset:
fr	Nous déclarons par la présente que les produits mentionnés dans le document sont conformes à la législation de la Communauté européenne et peuvent porter le marquage CE. Ces modèles sont conformes aux directives suivantes et aux normes connexes :
el	Με την παρούσα δήλωση πιστοποιείται ότι τα προϊόντα που αναφέρονται στην παρούσα πληρούν τις απαιτήσεις της Ευρωπαϊκής Κοινωνικής Νομοθεσίας και μπορούν να φέρουν τη σήμανση CE. Τα μοντέλα αυτά συμμορφώνονται με τις ακόλουθες Οδηγίες και τα σχετικά Πρότυπα.
hu	Ez annak tanúsítására szolgál, hogy a dokumentumban felsorolt termékek megfelelnek az Európai közösségi jog követelményeinek és viselheti a CE jelzést. Ezek a modellek eleget tesznek a következő irányelveknek és vonatkozó szabványoknak.
hr	Ovo je potvrda da proizvodi koji su navedeni u ovom dokumentu odgovaraju zakonima europske zajednice i da nose CE oznaku. Ovi modeli zadovoljavaju sljedeće direktive i odgovarajuće standarde.
it	Si certifica che i prodotti elencati nel presente documento soddisfanno i requisiti della legislazione della Comunità Europea e possono recare il marchio CE. Questi modelli sono conformi alle seguenti norme e direttive:
lt	Šiuo patvirtiname kad šiame dokumente paminėti produktai atitinka Europos Bendrijos įstatymų reikalavimus ir jie gali būti pažymėti CE ženklu. Šie modeliai atitinka sekančias direktyvas ir standartus.
lv	Ar šo tiek apstiprināts, ka šajā dokumentā uzskaitītie izstrādājumi atbilst Eiropas Kopienas Likuma prasībām un var tikt marķēti ar emblēmu CE. Šie modeļi atbilst sekojošajām Direktīvām un attiecīgajām Normām.
nl	Hiermee wordt gecertificeerd dat de producten die in deze lijst staan opgesomd, voldoen aan de wettelijke voorschriften van de Europese Gemeenschap en mogen worden voorzien van de CE markering. Deze modellen voldoen aan de volgende richtlijnen en bijbehorende normen:
no	Dette sertifiserer at produktene som er nevnt i dette dokumentet oppfyller kravene som stilles av EU, og at de dermed kan CE-merkes. Disse modellene tilfredsstiller følgende direktiver og relaterte standarder:
pl	Niniejszym zaświadcza się, że produkty wymienione w niniejszym dokumencie spełniają wymogi Prawa Wspólnoty Europejskiej i mogą nosić oznakowanie CE. Modele te spełniają wymogi następujących dyrektyw i powiązanych norm.
pt	O presente documento certifica que os produtos listados neste documento atendem aos requisitos das Leis da Comunidade Europeia e podem levar a marca CE. Esses modelos estão de acordo com as seguintes diretivas e padrões relacionados.
ro	Prin prezenta se atestă faptul că produsele menționate în acest document îndeplinesc cerințele de Drept Comunitar European și pot purta sigla C.E. Aceste modele sunt în conformitate cu următoarele directive și standarde asociate.
ru	Настоящим удостоверяется, что перечисленные в этом документе изделия соответствуют требованиям законов Европейского Союза и могут быть обозначены знаком CE. Эти модели отвечают требованиям следующих директив и соответствующих стандартов.
sl	To služi kot potrđitev, da izdelki, ki so navedeni v tem dokumentu, ustrezajo zahtevam zakonodaje Evropske skupnosti in so lahko opremljeni z oznako CE. Ti modeli so v skladu z naslednjimi direktivami in povezanimi standardi.
sk	Týmto vyhlasujeme, že výrobky uvedené v tomto dokumente, splňajú požiadavky zákonov ES a môžu byť označené značkou CE. Tieto modely vyhovujú nasledujúcim smerniciam príslušným normám.
sv	Härmed försäkras att produkterna som finns listade i detta dokument uppfyller kraven i Europeiska gemenskapens lagstiftning och kan förses med CE-märket. Modellerna uppfyller följande direktiv och tillhörande normer.
tr	Bu belgede belirtilen ürünlerin Avrupa Birliği Yasası gereksinimlerini karşılayarak CE işareti taşıyabilmelerini onaylamak içindir. Bu modeller aşağıdaki Direktif ve ilgili Standartlarla uyumludur



# SC180HEU Owner's Manual

en Directive: 2006/42/EC	hu Irányelv: 2006/42/EC	pt Diretiva: 2006/42/EC
bg Директива: 2006/42/EC	el Οδηγία: 2006/42/EC	ru Директива: 2006/42/EC
cs Směrnice č. 2006/42/EC	hr Direktiva: 2006/42/EC	ro Directive: 2006/42/EC
da Direktiv: 2006/42/EF	it Direttiva: 2006/42/EF	sl Direktiva: 2006/42/EF
de Richtlinie: 2006/42/EG	lt Direktyva: 2006/42/EG	sk Smernica: 2006/42/EG
es Directriz: 2006/42/EC	lv Direktīva: 2006/42/EC	sv Direktiv: 2006/42/EC
et Direktiiviga: 2006/42/EÜ	nl Richtlijn: 2006/42/EÜ	tr Direktif: 2006/42/EÜ
fi Direktiivi: 2006/42/EC	no Direktiv: 2006/42/EC	
fr Directives : 2006/42/CE	pl Dyrektywy: 2006/42/CE	

en Model	Guaranteed Sound Power Level	Measured Sound Power Level	Sound Pressure Level at Operator's Ear (1)	Engine Net Power	Hand/Arm Vibration (2)	Mass
bg Модел	Гарантирано ниво на звука	Измерено ниво на звука	Налягане на звука, измерено на нивото на ухото на оператора (1)	Мощност на двигателя	Вибрация на дланта и на ръката (2)	Маса
cs Model	Garantovaná hladina akustického výkonu	Změřená hladina akustického výkonu	Hladina akustického tlaku naměřená u ucha obsluhující osoby (1)	Užitečný výkon motoru	Vibrace rukou/paží (2)	Váha
da Model	Garanteret støjriveau	Målt støjriveau	Lydtryksniveau ved brugerens øre (1)	Maskine Netto kraft	Vibration af hånd/arm (2)	Vægt
de Modell	Garantierter Schalleistungspegel	Gemessener Schalleistungspegel	Schalldruckpegel am Ohr der Bedienungsperson (1)	Motornettoleistung	Vibrationen an Hand/Arm (2)	Masse
es Modelo	Nivel garantizado de potencia acústica	Nivel medido de potencia acústica	Nivel de presión acústica en el oído del operador (1)	Potencia neta del motor	Vibración mano / brazo (2)	Masa
et Mudel	Garanteeritud helivõimsuse tase	Mõõdetud helivõimsuse tase	Helirõhu tase kasutaja kõrvajuures (1)	Masin puhas tööväg	Võkumine käsi / käsivars (2)	Massi
fi Malli	Taattu äänitehotaso	Mitattu äänitehotaso	Äänenpaine taso käyttäjän korvan tasolla (1)	Moottorin nettoteho	Käden/käsivarren värinä (2)	Paino
fr Modèle	Niveau de bruit garanti	Niveau de bruit mesuré	Niveau sonore au niveau de l'oreille de l'opérateur (1)	Puissance nette du moteur	Vibrations au niveau de la main/du bras (2)	Masse
el Μοντέλο	Εγγυημένη στάθμη ηχητικής ισχύος	Μετρηθείσα στάθμη ηχητικής ισχύος	Στάθμη ηχητικής πίεσης στο αυτί του χειριστή (1)	Καθαρή ισχύς κινητήρα	Χειροβραχίονα κί δόνηση (2)	Μάζα
hu Model	Garantált hangteljesítmény szint	Mért hangteljesítmény szint	Hangnyomás szint a gépkezelő fülénél (1)	Motor hasznos teljesítménye	Kéz/kar vibráció (2)	Tömeg
hr Model	Zajamčena razina snage zvuka	Izmerjena razina snage zvuka	Razina zvučnog tlaka na uhu rukovatelja (1)	Neto snaga motora	Vibracije šake/ruke (2)	Masa
it Modello	Livello acustico garantito	Livello acustico misurato	Livello di pressione acustica all'orecchio dell'operatore (1)	Potenza netta motore	Vibrazioni a mani/braccia (2)	Massa
lt Modelis	Garantuotas triukšmo lygis	Pamatuotas triukšmo lygis	Garso spaudimo lygis įrangos naudotojui (1)	Variklio bendras galingumas	Rankenos vibracija (2)	Masė
lv Modelis	Garantētais skaņas jaudas līmenis	Izmērītais skaņas jaudas līmenis	Skaņas spiediena līmenis pie operatora auss (1)	Dzinēja neto jauda	Rokas/pleca vibrācija (2)	Masa
nl Model	Gegarandeerd geluidsdrukniveau	Gemeten geluidsdrukniveau	Geluidsdrukniveau bij het oor van de gebruiker (1)	Netto motorvermogen	Trilling van hand/arm (2)	Mass
no Modell	Garantert lydstrykenivå	Målt lydstrykenivå	Lydtrykk-nivå ved operatørens øre (1)	Motorens netto krefter	Hånd/arm-vibrasjon (2)	Masse
pl Model	Gwarantowany poziom mocy akustycznej	Zmierzony poziom mocy akustycznej	Poziom ciśnienia akustycznego w uchu operatora (1)	Moc netto silnika	Drgania ręki/ramienia (2)	Masa
pt Modelo	Nível de potência de som garantido	Nível de potência de som medido	Níveis de pressão do som no ouvido do operador (1)	Potência útil do motor	Vibração na mão/braço (2)	Massa
ro Model	Nivel de zgomot garantat	Nivel de zgomot măsurat	Nivel de presiune acustică la urechea operatorului (1)	Putere netă motor	Vibrație mână/braț (2)	Masă
ru Модель	Гарантированный уровень звуковой мощности	Измеренный уровень звуковой мощности	Уровень звукового давления на месте оператора (1)	Полезная мощность двигателя	Интенсивность вибрации на ладонях/руках (2)	Вес
sl Model	Zajamčena raven zvočne moči	Izmerjena raven zvočne moči	Raven zvočnega tlaka pri užesu uporabnika (1)	Izhodna moč motorja	Tresljaji na rokah (2)	Masa
sk Model	Zaručená hladina akustického výkonu	Nameraná hladina akustického výkonu	Hladina akustického tlaku pôsobiaceho na ucho obsluhy (1)	čistý výkon motora	Ruka/Rameno Vibrácia (2)	Masa
sv Modell	Garanterad ljudeffektivnivå	Uppmått ljudeffektivnivå	Ljudtrycksnivå vid operatörens öra (1)	Motor effekt netto	Hand-/ armvibrationer (2)	Massa
tr Model	Garantili Ses Gücü Seviyesi	Ölçülen Ses Gücü Seviyesi	Operatörün Kulakındaki Ses Basınç Seviyesi (1)	Makine Net Gücü	El/Kol Titreşimi (2)	Ağırlık
SC180HEU	105 dB(A)	104 dB(A)	84 dB(A)	4.1kW	24.8 m/s <sup>2</sup>	158 kg

(1) ISO 5395-1:2013 F.7 (EN 4871:1996)  
(2) ISO 5395-1:2013 G.8 (EN 12096:1997, D.1)



## SC180HEU Owner's Manual

en	Manufacturing Place / Keeper of Documentation	el	Τόπος κατασκευής / Υπεύθυνος τήρησης αρχείων τεκμηρίωσης	pl	Miejsce produkcji / Osoba odpowiedzialna za przechowywanie dokumentów
bg	Място на производство / Архивар	hu	Gyártás helye / A dokumentáció őrzője	pt	Local de fabrico / Responsável pela Documentação
cs	Místo výroby / Držitel dokumentace	hr	Mjesto proizvodnje / Čuvar dokumentacije	ro	Loc de fabricație / Păstrător documentație
da	Fremstillingssted / Indehaver af dokumentationen	it	Sede di produzione / Archiviare di documentazione	ru	Место производства / Владелец документации
de	Herstellungsort / Verantwortlicher für die Dokumentation	lt	Pagamimo vieta / Dokumentacijos turėtojas	sl	Kraj izdelave / Hranitelj dokumentacije
es	Lugar de manufactura / Guardián de documentación	lv	Ražošanas vieta / Dokumentācijas glabātājs	sk	Miesto výroby / Dokumentácia majiteľa
et	Valmistamiskoht / Dokumentatsiooni hoidja	nl	Productieplaats / Documentatiebeheerder	sv	Tillverkningsplats / Dokumentförvaring
fi	Valmistuspaikka / Asiakirjojen haltija	no	Produksjonssted / Dokumentasjonsholder	tr	Üretim Yeri / Doküman Sorumlusu
fr	Lieu de fabrication / Personne chargée de conserver la documentation				

1803 S.W. Jefferson  
Lees Summit, MO 64063-  
0308 USA

Jeroen Engelen  
Schepersweg 4a 6049CV  
Herten, NL

Ted Melin  
Engineering Manager

Part No. 371509  
Revision: F102215A

10/05/2015